

NUOVA

POLAR+25.MB

Double Duct Air Conditioner



INSTALLATION AND USER MANUAL

BEFORE INSTALLING AND USING THIS AIR CONDITIONER PLEASE READ ALL INSTRUCTIONS CAREFULLY.

1. GENERAL INFORMATION

1.1 INTRODUCTION.....	5
1.2 IMPORTANT SAFETY INSTRUCTIONS.....	5
1.3 RECIVING THE GOODS.....	6
1.4 HANDLING.....	6
1.5 LIST OF ACCESSORIES.....	6
1.6 TECHNICAL FEATURES.....	7





2. INSTALLATION

2.1 POSITIONING OF THE AIR CONDITIONER.....	8
2.2 PAPER TEMPLATE.....	8
2.3 DRILLING THE WALL.....	10
2.4 FASTENING THE BRACKET.....	10
2.5 INSTALLATION OF THE PIPES.....	11
2.6 FITTING THE GRATINGS.....	11
2.7 FITTING THE AIR CONDITIONER ON BRACKET.....	12

3. USE AND MAINTENANCE

3.1 INTRODUCTION OF LCD ICONS.....	13
3.2 REMOTE CONTROL FUNCTIONS	13
3.3 HEATING MODE.....	14
3.4 COOLING MODE.....	14
3.5 DRY MODE.....	15
3.6 FAN MODE.....	15
3.7 SLEEP MODE.....	16
3.8 AUTO MODE.....	16
3.9 TIMER OFF FUNCTION.....	17
3.10 TIMER ON FUNCTION.....	17
3.11 ELECTRICAL HEAT FUNCTION.....	18
3.12 ON BOARD CONTROL FUNCTION.....	19
3.13 WIFI CONNECTION AND INSTRUCTION FOR USE.....	20
3.14 INSTALL AND CHANGE THE BATTERY.....	20
3.15 FRESH AIR SYSTEM.....	20
3.16 MAINTENANCE.....	21
3.17 PROBLEM SOLVING.....	22

AS A SAFETY PRECAUTION

	WARNING	THIS SYMBOL THAT THIS APPLIANCE USED A FLAMMABLE REFRIGERANT. IF THE REFRIGERANT IS LEAKED AND EXPOSED TO AN EXTERNAL IGNITION SOURCE, THERE IS A RISK OF FIRE.
	CAUTION	THIS SYMBOL THAT THE OPERATION MANUAL SHOULD BE READ CAREFULLY.
	CAUTION	THIS SYMBOL THAT A SERVICE PERSONNEL SHOULD BE HANDLING THIS EQUIPMENT WITH REFERENCE TO THE INSTALLATION MANUAL.
	CAUTION	THIS SYMBOL THAT INFORMATION IS AVAILABLE SUCH AS THE OPERATING MANUAL OR INSTALLATION MANUAL.

The appliance is not accessible to general public.

This appliance can be used by children aged from 8 years and above and persons with reduced physical, sensory or mental capabilities or lack of experience and knowledge if they have been given supervision or instruction concerning use of the appliance in a safe way and understand the hazards involved

Children should be supervised to ensure that they do not play with the appliance.



Caution, risk of fire



No smoking

WARNING

Do not use means to accelerate the defrosting process or to clean, other than those recommended by the manufacturer.

The appliance shall be stored in a room without continuously operating ignition sources (for example: open flames, an operating gas appliance or an operating electric heater.)

Do not pierce or burn.

Be aware that refrigerants may not contain an odour.

The appliance shall be stored in a well-ventilated area where the room size corresponds to the room area as specified for operation;

-a warning that the appliance shall be stored in a room without continuously operating open flames (for example an operating gas appliance) and ignition sources (for example an operating electric heater).

The appliance shall be stored so as to prevent mechanical damage from occurring.

The compliance with national gas regulations shall be observed;

Min applicable area of this machine is 15m .

Please ensure that there are no obstacles in front of the machine, keep ventilation openings clear of obstruction.

Servicing shall be performed only as recommended by the manufacturer.

Any person who is involved with working on or breaking into a refrigerant circuit should hold a current valid certificate from an industry-accredited assessment authority, which authorises their competence to handle refrigerants safely in accordance with an industry recognised assessment specification.

Servicing shall only be performed as recommended by the equipment manufacturer. Maintenance and repair requiring the assistance of other skilled personnel shall be carried out under the supervision of the person competent in the use of flammable refrigerants.

Before servicing the appliance

Checks to the area:

Prior to beginning work on systems containing flammable refrigerants, safety checks are necessary to ensure that the risk of ignition is minimised. For repair to the refrigerating system, the following precautions shall be complied with prior to conducting work on the system

Work procedure:

Work shall be undertaken under a controlled procedure so as to minimise the risk of a flammable gas or vapour being present while the work is being performed.

General work area:

All maintenance staff and others working in the local area shall be instructed on the nature of work being carried out. Work in confined spaces shall be avoided. The area around the workspace shall be sectioned off. Ensure that the conditions within the area have been made safe by control of flammable material.

Checking for presence of refrigerant:

The area shall be checked with an appropriate refrigerant detector prior to and during work, to ensure the technician is aware of potentially flammable atmospheres. Ensure that the leak detection equipment being used is suitable for use with flammable refrigerants, i.e. non-sparking, adequately sealed or intrinsically safe.

Presence of fire extinguisher:

If any hot work is to be conducted on the refrigeration equipment or any associated parts, appropriate fire extinguishing equipment shall be available to hand. Have a dry powder or CO2 fire extinguisher adjacent to the charging area.

No ignition sources:

No person carrying out work in relation to a refrigeration system which involves exposing any pipe work that contains or has contained flammable refrigerant shall use any sources of ignition in such a manner that it may lead to the risk of fire or explosion. All possible ignition sources, including cigarette smoking, should be kept sufficiently far away from the site of installation, repairing, removing and disposal, during which flammable refrigerant can possibly be released to the surrounding space. Prior to work taking place, the area around the equipment is to be surveyed to make sure that there are no flammable hazards or ignition risks.

Ensure that the area is in the open or that it is adequately ventilated before breaking into the system or conducting any hot work. A degree of ventilation shall continue during the period that the work is carried out. The ventilation should safely disperse any released refrigerant and preferably expel it externally into the atmosphere.

Checks to the refrigeration equipment:

Where electrical components are being changed, they shall be fit for the purpose and to the correct specification. At all times the manufacturer's maintenance and service guidelines shall be followed. If in doubt consult the manufacturer's technical department for assistance. The following

checks shall be applied to installations using flammable refrigerants:

- the charge size is in accordance with the room size within which the refrigerant containing parts are installed;
- the ventilation machinery and outlets are operating adequately and are not obstructed;
- if an indirect refrigerating circuit is being used, the secondary circuit shall be checked for the presence of refrigerant;
- marking to the equipment continues to be visible and legible. Markings and signs that are illegible shall be corrected;
- refrigeration pipe or components are installed in a position where they are unlikely to be exposed to any substance which may corrode refrigerant containing components, unless the components are constructed of materials which are inherently resistant to being corroded or are suitably protected against being so corroded.

Checks to electrical devices:

Repair and maintenance to electrical components shall include initial safety checks and component inspection procedures. If a fault exists that could compromise safety, then no electrical supply shall be connected to the circuit until it is satisfactorily dealt with. If the fault cannot be corrected immediately but it is necessary to continue operation, an adequate temporary solution shall be used. This shall be reported to the owner of the equipment so all parties are advised.

Initial safety checks shall include:

- that capacitors are discharged: this shall be done in a safe manner to avoid possibility of sparking;
- that no live electrical components and wiring are exposed while charging, recovering or purging the system;
- that there is continuity of earth bonding.

Repairs to sealed components:

During repairs to sealed components, all electrical supplies shall be disconnected from the equipment being worked upon prior to any removal of sealed covers, etc. If it is absolutely necessary to have an electrical supply to equipment during servicing, then a permanently operating form of leak detection shall be located at the most critical point to warn of a potentially hazardous situation.

Particular attention shall be paid to the following to ensure that by working on electrical components, the casing is not altered in such a way that the level of protection is affected. This shall include damage to cables, excessive number of connections, terminals not made to original specification, damage to seals, incorrect fitting of glands, etc. Ensure that apparatus is mounted securely.

Ensure that seals or sealing materials have not degraded such that they no longer serve the purpose of preventing the ingress of flammable atmospheres. Replacement parts shall be in NOTE *The use of silicon sealant may inhibit the effectiveness of some types of leak detection equipment. Intrinsically safe components do not have to be isolated prior to working on them.*

Repair to intrinsically safe components:

Do not apply any permanent inductive or capacitance loads to the circuit without ensuring that this will not exceed the permissible voltage and current permitted for the equipment in use. Intrinsically safe components are the only types that can be worked on while live in the presence of a flammable atmosphere. The test apparatus shall be at the correct rating. Replace components only with parts specified by the manufacturer. Other parts may result in the ignition of refrigerant in the atmosphere from a leak

Cabling:

Check that cabling will not be subject to wear, corrosion, excessive pressure, vibration, sharp edges or any other adverse environmental effects. The check shall also take into account the effects of ageing or continual vibration from sources such as compressors or fans.

Detection of flammable refrigerants:

Under no circumstances shall potential sources of ignition be used in the searching for or detection of refrigerant leaks. A halide torch (or any other detector using a naked flame) shall not be used.

Leak detection methods:

The following leak detection methods are deemed acceptable for systems containing flammable refrigerants.

Electronic leak detectors shall be used to detect flammable refrigerants, but the sensitivity may not be adequate, or may need re-calibration. (Detection equipment shall be calibrated in a refrigerant-free area.) Ensure that the detector is not a potential source of ignition and is suitable for the refrigerant used. Leak detection equipment shall be set at a percentage of the LFL of the refrigerant and shall be calibrated to the refrigerant employed and the appropriate percentage of gas (25 % maximum) is confirmed.

Leak detection fluids are suitable for use with most refrigerants but the use of detergents containing chlorine shall be avoided as the chlorine may react with the refrigerant and corrode the copper pipe-work.

If a leak is suspected, all naked flames shall be

removed/extinguished.

If a leakage of refrigerant is found which requires brazing, all of the refrigerant shall be recovered from the system, or isolated (by means of shut off valves) in a part of the system remote from the leak. Oxygen free nitrogen (OFN) shall then be purged through the system both before and during the brazing process.

Removal and evacuation:

When breaking into the refrigerant circuit to make repairs-or for any other purpose-conventional procedures shall be used. However, it is important that best practice is followed since flammability is a consideration.

The following procedure shall be adhered to:

- remove refrigerant;
- purge the circuit with inert gas;
- evacuate;
- purge again with inert gas;
- open the circuit by cutting or brazing.

The refrigerant charge shall be recovered into the correct recovery cylinders. The system shall be “flushed” with OFN to render the unit safe. This process may need to be repeated several times. Compressed air or oxygen shall not be used for this task.

Flushing shall be achieved by breaking the vacuum in the system with OFN and continuing to fill until the working pressure is achieved, then venting to atmosphere, and finally pulling down to a vacuum. This process shall be repeated until no refrigerant is within the system. When the final OFN charge is used, the system shall be vented down to atmospheric pressure to enable work to take place. This operation is absolutely vital if brazing operations on the pipework are to take place. Ensure that the outlet for the vacuum pump is not close to any ignition sources and there is ventilation available.

Charging procedures:

In addition to conventional charging procedures, the following requirements shall be followed.

- Ensure that contamination of different refrigerants does not occur when using charging equipment. Hoses or lines shall be as short as possible to minimise the amount of refrigerant contained in them.
- Cylinders shall be kept upright.
- Ensure that the refrigeration system is earthed prior to charging the system with refrigerant.
- Label the system when charging is complete (if not already).
- Extreme care shall be taken not to overfill the refrigeration system.

Prior to recharging the system it shall be pressure tested with OFN. The system shall be leak tested on completion of charging but prior to commissioning. A follow up leak test shall be carried out prior to leaving the site.

Decommissioning:

Before carrying out this procedure, it is essential that the technician is completely familiar with the equipment and all its detail. It is recommended good practice that all refrigerants are recovered safely. Prior to the task being carried out, an oil and refrigerant sample shall be taken in case analysis is required prior to re-use of reclaimed refrigerant. It is essential that electrical power is available before the task is commenced.

- a) Become familiar with the equipment and its operation.
- b) Isolate system electrically.
- c) Before attempting the procedure ensure that:
 - mechanical handling equipment is available, if required, for handling refrigerant cylinders;
 - all personal protective equipment is available and being used correctly;
 - the recovery process is supervised at all times by a competent person;
 - recovery equipment and cylinders conform to the appropriate standards.
- d) Pump down refrigerant system, if possible.
- e) If a vacuum is not possible, make a manifold so that refrigerant can be removed from various parts of the system.
- f) Make sure that cylinder is situated on the scales before recovery takes place.
- g) Start the recovery machine and operate in accordance with manufacturer's instructions.
- h) Do not overfill cylinders. (No more than 80 % volume liquid charge).
- i) Do not exceed the maximum working pressure of the cylinder, even temporarily.
- j) When the cylinders have been filled correctly and the process completed, make sure that the cylinders and the equipment are removed from site promptly and all isolation valves on the equipment are closed off.
- k) Recovered refrigerant shall not be charged into another refrigeration system unless it has been cleaned and checked.

Recovery:

When removing refrigerant from a system, either for servicing or decommissioning, it is recommended good practice that all refrigerants are removed safely.

When transferring refrigerant into cylinders, ensure that only appropriate refrigerant recovery cylinders are employed. Ensure that the correct

number of cylinders for holding the total system charge are available. All cylinders to be used are designated for the recovered refrigerant and labelled for that refrigerant (i.e. special cylinders for the recovery of refrigerant). Cylinders shall be complete with pressure relief valve and associated shut-off valves in good working order. Empty recovery cylinders are evacuated and, if possible, cooled before recovery occurs.

The recovery equipment shall be in good working order with a set of instructions concerning the equipment that is at hand and shall be suitable for the recovery of flammable refrigerants. In addition, a set of calibrated weighing scales shall be available and in good working order. Hoses shall be complete with leak-free disconnect couplings and in good condition. Before using the recovery machine, check that it is in satisfactory working order, has been properly maintained and that any associated electrical components are sealed to prevent ignition in the event of a refrigerant release. Consult manufacturer if in doubt.

The recovered refrigerant shall be returned to the refrigerant supplier in the correct recovery cylinder, and the relevant Waste Transfer Note arranged. Do not mix refrigerants in recovery units and especially not in cylinders.

If compressors or compressor oils are to be removed, ensure that they have been evacuated to an acceptable level to make certain that flammable refrigerant does not remain within the lubricant. The evacuation process shall be carried out prior to returning the compressor to the suppliers. Only electric heating to the compressor body shall be employed to accelerate this process. When oil is drained from a system, it shall be carried out safely.

1.1 INTRODUCTION

PLEASE NOTE: Do not dispose of any packaging until the installation of the air conditioner is completed.

After having removed the packing, check that all the content is intact and complete. (See list of accessories). In the event of missing parts, contact your retailer.

This air conditioner has been designed to cool or heat the air of a room and should only be used for this purpose.

The manufacturer cannot be held liable for damage caused to property or injury to persons or animals due to incorrect installation, regulation and maintenance or improper use.

This air conditioner contains R32 refrigerant: at the end of its life, the disposal of this air conditioner must be in accordance with the strict regulation governing the recycling of this product, please operate with caution during the disposal. Please contact your local authority for regulatory advice.

Do not switch on before having totally assembled the air conditioner and before installing in its correct operating position.

Before starting the appliance, check that it is correctly earthed, according to the legislation in force in the country concerned.

1.2 IMPORTANT SAFETY INSTRUCTIONS



When using electrical appliances, basic safety precautions should always be followed:

Do not place objects on the product or allow objects to obstruct the inlet or outlet openings. Extreme care should be taken when any product is used by, or near children and pets, and whenever the product is left operating and unattended.

Please note:

Before operating the product remove the air conditioner from its packaging and check it is in good condition.

Do not let children play with the packaging, for example plastic bags.

Do not operate any product with a damaged cord or plug, or after the air conditioner malfunctions, has been dropped, or damaged in any manner.

Return the air conditioner to an authorised service center for examination and repair to avoid a hazard.

Do not attempt to repair or adjust any electrical or mechanical functions on this air conditioner as this may void warranty, contact your service engineer.

Always operate the product from a power source of the same voltage, frequency and rating as indicated on the product identification plate. This air conditioner is not intended for use in wet or damp locations.

Do not place the air conditioner near an open flame, cooking or heating appliance, or hot surface.

Do not let the power cord hang over the edge of a table or counter. Arrange the power cord away from an area where it may be tripped over.

Never place the power cord under a carpet or rug. Do not operate the air conditioner in areas where petrol, paint, or other flammable liquids are used or stored.

Do not carry out any cleaning or maintenance or access internal parts until the air conditioner has been disconnected from the mains electricity supply.

Do not alter the safety or regulating devices without the permission and instructions of the air conditioner manufacturer.

Do not pull, remove or twist the electric cable connected to the air conditioner, even if disconnected from the mains electricity supply.

Avoid prolonged direct contact with the flow of the air from the air conditioner and the room being closed with no ventilation for a long period of time.

Repair or maintenance work must be carried out by a service engineer or by qualified technicians in compliance with the instructions given in this booklet. Do not alter the appliance, since hazardous situations could be created while the manufacturer of the appliance will not be liable for any damage or injury caused.

This instruction booklet is an integral part of the appliance and should therefore be carefully preserved and always accompany the appliance in the event of transfer to another owner or user or another installation engineer.

Should the booklet be damaged or lost, please request an additional.

1.3 RECEIVING THE GOODS

The air conditioner is delivered in a protective packaging and is accompanied by an instruction manual. This manual is an integral part of the air conditioner and should therefore be carefully read and preserved.

When the air conditioner is unpacked, please check that the air conditioner and the accessory pack are complete and undamaged.

1.4 HANDLING

Be fully aware of the weight of the air conditioner before attempting to lift it. Take all necessary precautions to avoid damaging the product or causing personal injury.

It is advisable to remove the packaging only when the air conditioner has been located in the point of installation.

Carefully remove the adhesive strips positioned on the air conditioner.

Packaging components must be disposed correctly and not left within reach of children, since they are a potential source of danger.

1.5 LIST OF ACCESSORIES(P0)

1. FASTENING BRACKET
2. REMOTE CONTROL
3. REMOTE CONTROL HOLDER
4. DRAINAGE PIPE
5. EXTERNAL GRATING
6. PLASTIC SHEET AIR PIPE
7. KIT OF SCREWS
8. GRATING FIXING CORD
9. INSTRUCTION MANUAL
- 10.PAPER TEMPLATE FOR WALL DRILLING
(See page)

This product can be connected only to a supply with system impedance no more than 0.193 ohm. In case necessary , please consult your supply authority for system impedance information.

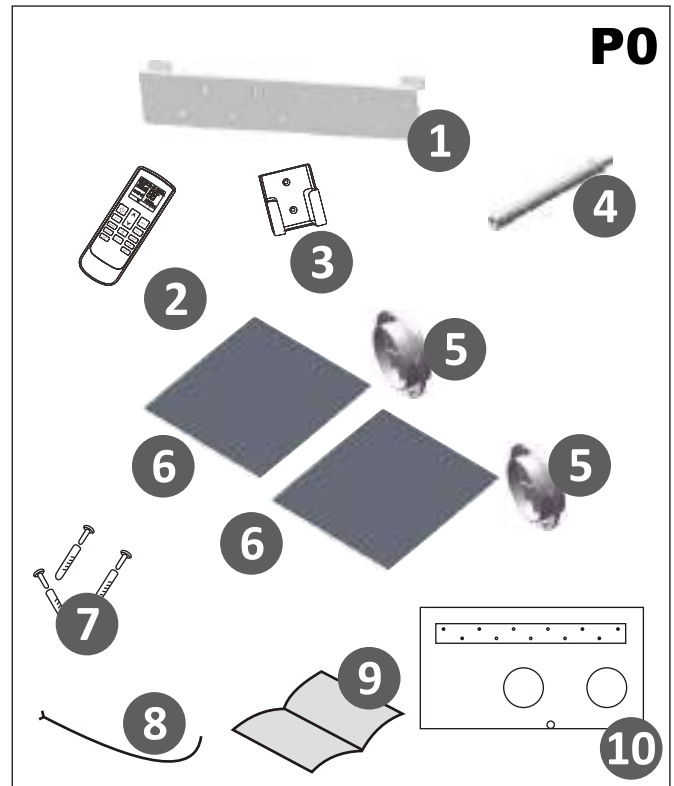

This product has been manufactured to comply with 2006/95/EC and with amendments 92/31/EE and 93/68/EEC



Waste electrical products should not be disposed of with household waste. Please recycle where facilities exist. Check with your Local Authority or retailer for recycling advice.



Any batteries used in the remote control contain materials, which are hazardous to the environment. They must be removed from the remote control when they reach the end of their life and disposed of responsibly.

1.6 TECHNICAL FEATURES (P1,P2)

Model	POLAR+25.MB
Cooling capacity* W	2500
Heating capacity* W	2500
Electrical Heater* W	-
Hot water capacity** W	-
Rated voltage (V/Hz)	230/50
Absorbed power in cooling* (W)	760
Absorbed current in cooling* (A)	3.4
Absorbed power in heating* (W)	628
Absorbed current in heating* (A)	2.83
Air flow (m ³ /h)	400
Dehumidification capacity* (L/24h)	16.08
Optional temperature (remote control)	18-30°C
Fuse (T3.15L)	250V
Refrigerant	R32
Global warmer potential (GWP)	675
Dimensions H/W/D (mm)	543x 935x198
Weight (kg)	35

*The above datas could be change in order to improve the performances

STANDARD TEST CONDITIONS -EN 14511-

OPERATING CONDITIONS IN COOLING AND DEHUMIDIFICATION MODE

- Inside 27°C DB; 19°C WB
- Outside 35°C DB; 24°C WB

OPERATING CONDITIONS IN HEATING MODE

- Outside 7°C DB; 6°C WB
- Inside 20°C DB

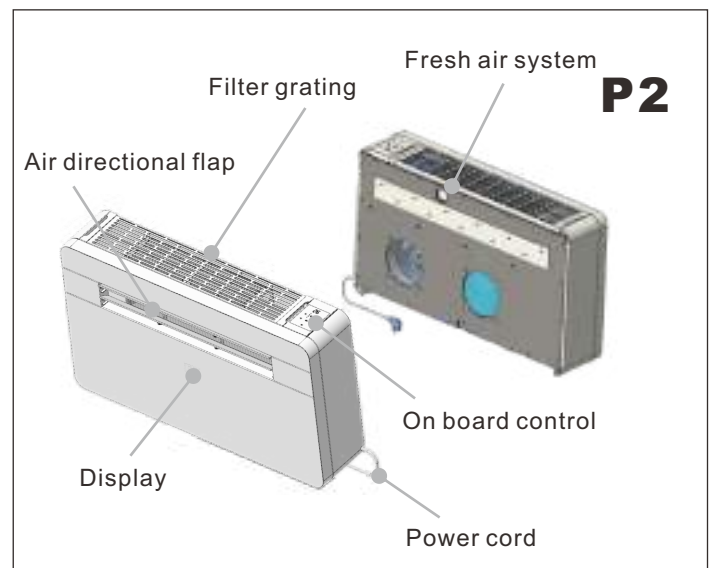
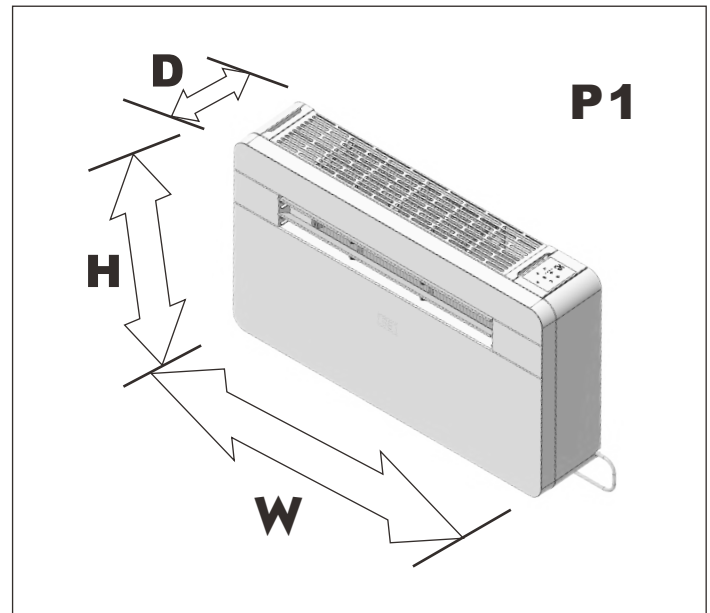

Light up: Power supply Light flickered: Wifi Pairing
Light up: Wifi Connected

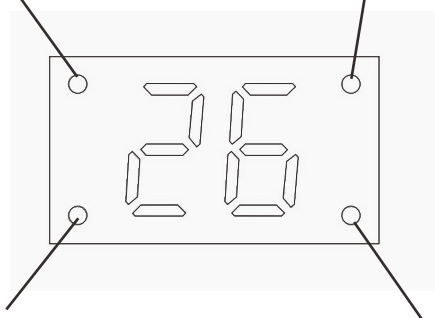

Light up: Night mode is on Light up: Compressor is on

The display will show both setting temperature and ambient temperature. After adjusting the setting temperature, the setting temperature will flash 15 times on the display, then the display will show the ambient temperature for 70 seconds. After that, the display will be off until next adjustment.

2.1 POSITIONING THE AIR CONDITIONER (P3)

To maintain the best performance from your air conditioner, prevent breakdowns or hazards, you must position it correctly. Please follow the guidelines and instruction below in full, as failure to do so could cause potential installation problems.

- The air conditioner must be installed on an exterior wall that has access to the out side with a minimum of 2 meters clearance to the outside.
- The air conditioner must be fitted leaving room all around as illustrated in the paper template
- The wall on which the air conditioner is installed must be sturdy and able to withstand the weight of the air conditioner.

After determining the best place for installation as described above, please check to ensure that the wall can be drilled in the chosen area without interfering with other structures or installations (beams, piers, pipes, wires, etc.). Please also ensure that there are no obstacles on the outside of the wall, which may obstruct air circulation through the drilled holes, for example: plants and their leaves, slats or panelling, drain pipes, overflows and gratings, etc.). Any obstruction could interfere with the correct performances of the air conditioner.

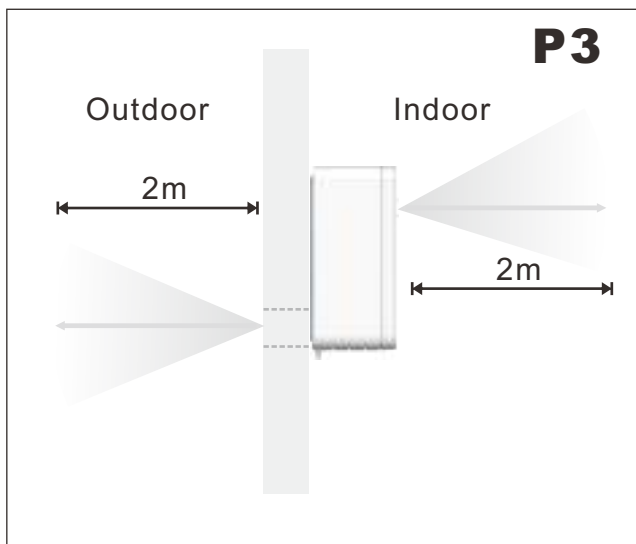

2.2 PAPER TEMPLATE (P4)

Fasten the template to the wall once the following guidelines have been thoroughly checked.

- Do not drill any holes until you are completely confident that there are no obstacles in the area you wish to drill and there are no obstructions, which could be hidden by the construction of the wall, for example:
Electrical wiring water & gas pipes or supporting lintels or beams.
- Ensure that a spirit level is used, as the air conditioner must be level.
- Follow the installation instructions in full.

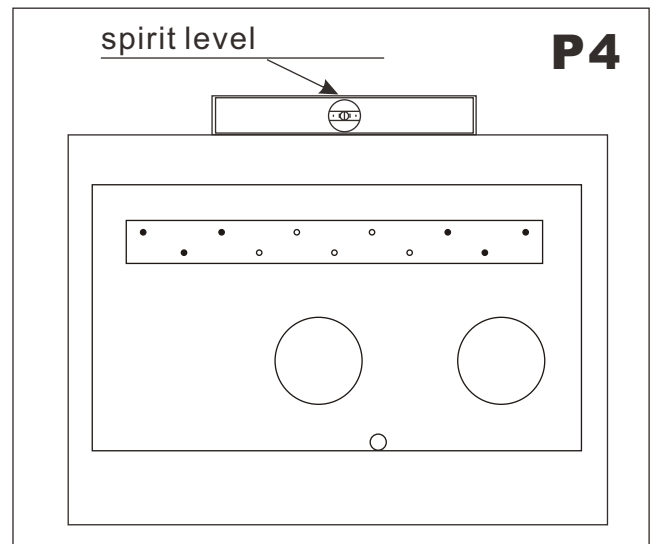

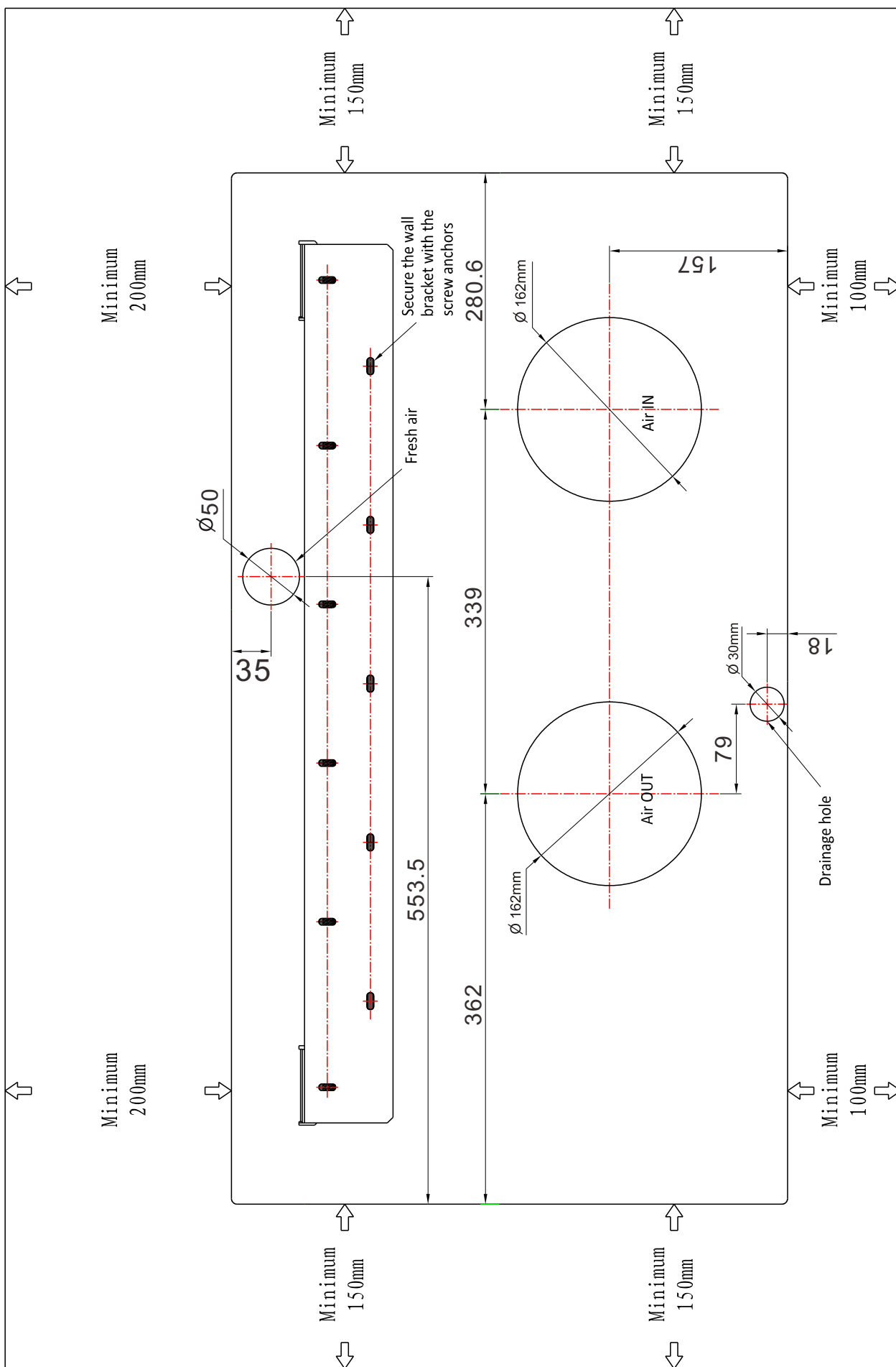

2.3 DRILLING THE WALL (P5)

Please note: If you are drilling the hole above ground floor level, please ensure that an area has been secured and while the holes are drilled the outside area is supervised, until drilling has been completed.

INTAKE AND OUTLET HOLES

- This operation should be carried out using the proper tools (diamond tip or core borers drills with high twisting torque and adjustable rotation speed).
- Fasten the template to the wall taking care to check the distance from the floor and or ceiling and keep it horizontal by using a spirit level.
- Use a pilot drill to mark the centre of each core hole to be drilled, Use a core boring head having a diameter of 162 mm to drill the two holes for intake and outlet the air.

 It is recommended that the holes must have a slightly downward inclination of 3-5 degrees to prevent any backflow of water from the pipes.



Indoor

Outdoor

DRAINAGE HOLE (P6)

Please read carefully the follow instructions:

drill a hole through the wall measuring 30mm in diameter in the position shown in the paper template. Drainage occurs by gravity.

For this reason, it is essential for the drain line to have a minimum downward inclination at least 3 degrees through out its length: connect the drain pipe (from rubber terminal) to the air conditioner (bottom of chassis)

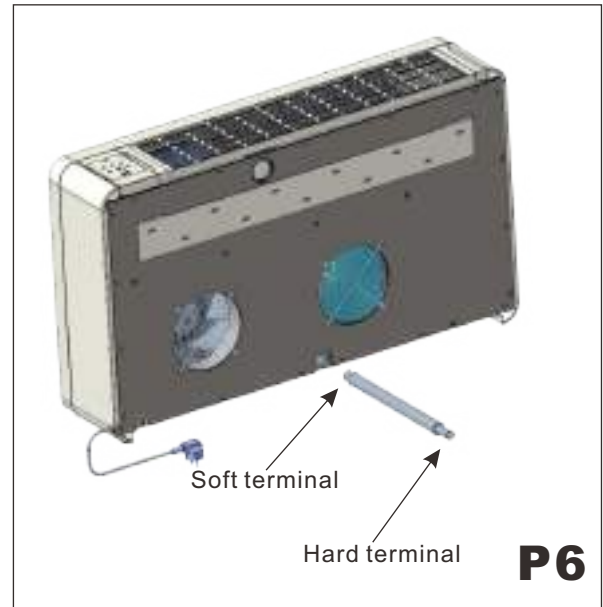

2.4 FASTENING THE BRACKET (P7)

- Drill the holes for anchoring the fastening bracket to the wall using preferably the 6 holes showed in black on the paper template. If the wall is not sturdy enough it is advisable to use extra anchor bolts using the holes showed in grey on the paper template.
- The anchor bolts provided require a 8mm holes; the wall should be inspected to determine if provided bolts are useful or if it is necessary to use a different anchorage. The manufacturer is not liable in case of underestimation of the structural consistency of the anchorage made at the time of installation.

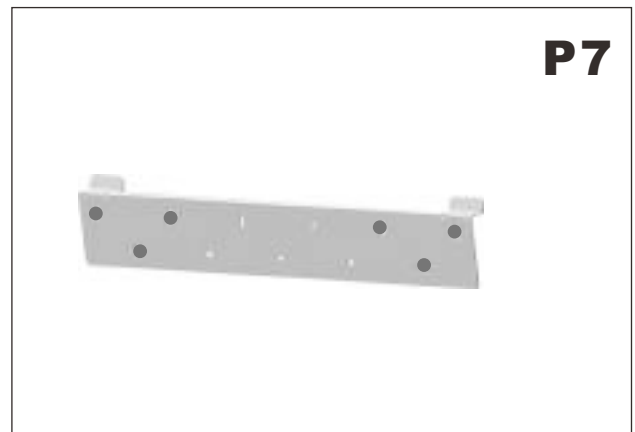

2.5 INSTALLATION OF THE PIPES (P8)

- After drilling the holes, the plastic pipes supplied with the air conditioner need to be fitted through them.
- Roll the sheet and insert it into the hole, paying attention to the joint line, which must be always upper position. Remember that the sheet must have the same inclination of the holes(min 3°).
- Insert the rings into the holes.

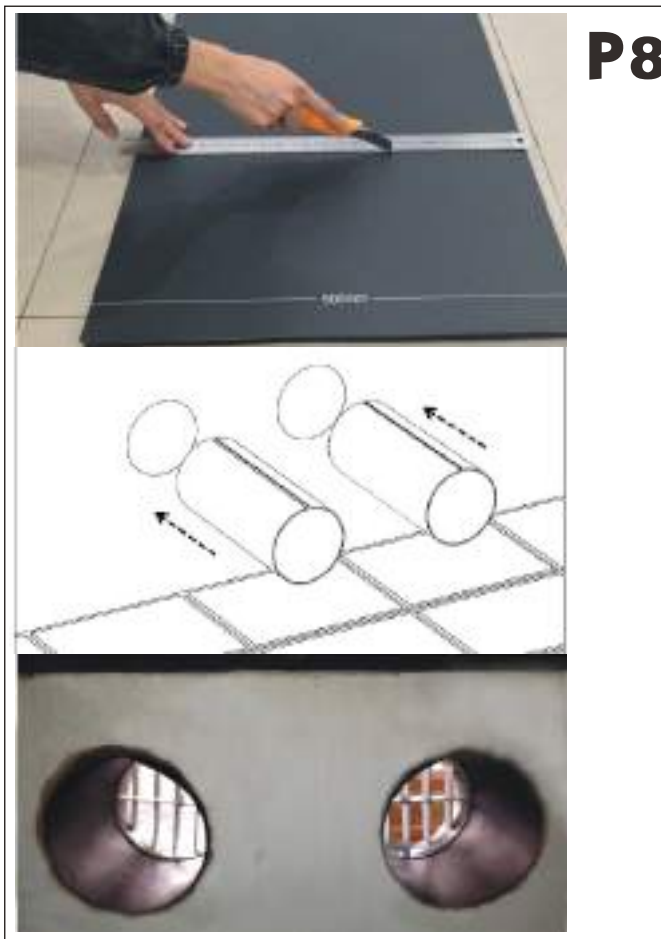

P8

2.6 FITTING THE GRATINGS (P9, P10,P11,P12)

To fit the external two gratings please proceed as follows: familiarise yourself with the fitting of the grating to the tube, before installation. Insert the cords through the centre of the grating. One grating fits on the outside of the tube and the other fits inside. The air discharge is the bigger hole and the grating therefore fits on the outside of the air discharge tube. Insert the supplied cord into the hole. Fold the outer grating in half grasping the cord with your

free hand. Insert your arm inside the pipe with the grating and push all the way to the outside. Let the grating unfold and pull the cord toward you. One grating fits on the outside of the tube and the other fits inside. With a little patience and manipulation the 2 gratings will fit the end of the tubes. Grasping the cord, insert your fingers between the fins and pull the grating toward you until the same is properly slipped in the pipe, keeping the fins in vertical position. If the external grating is accessible to prevent its removal, it is recommended to fasten it to the wall with wall plugs and screws with a diameter of 6 mm. Tighten the cord and fasten it to the dent on the internal flanges.



P10



P11

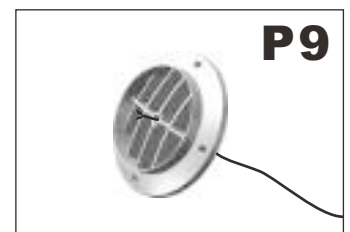
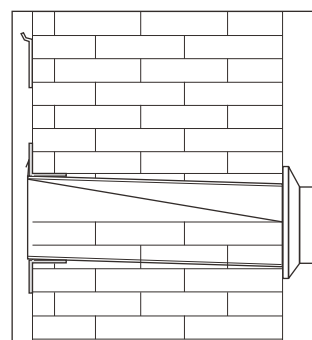

P9

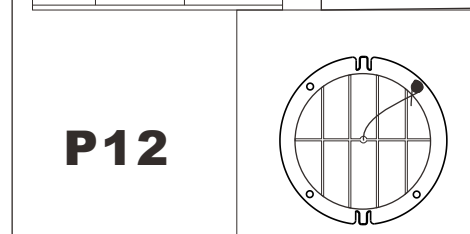

P12

2.7 FITTING THE AIR CONDITIONER ON BRACKET (P13, P14)

After checking again that the fastening bracket is securely fastened to the wall, and that any necessary preparations for electric connection and condensate drainage (if it needs) have been made, fasten the air conditioner to its supporting bracket.

Lift it up by holding the sides at the bottom. Tilt the air conditioner slightly toward you to facilitate the operation of fastening it to the bracket. The air conditioner can now be pushed firmly against the wall. Inspect carefully the installation to make sure that the insulating back panel must fit firmly against the wall and there are no fissures at the back of the air conditioner and that the two plastic semicircle on the back side of the air conditioner are placed inside of the two plastic hoses fixed inside the wall.









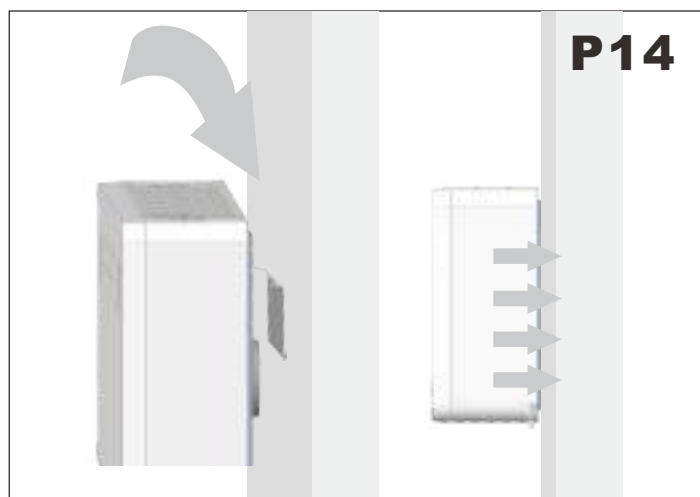
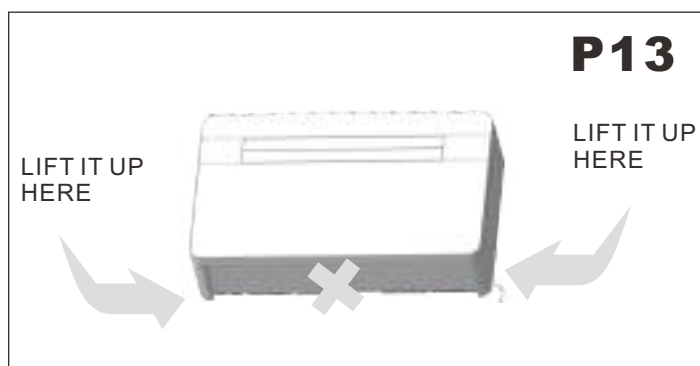







The appliance shall not be installed the laundry.

The appliance must be positioned so that the plug is accessible.

The appliance shall be installed in accordance with national wiring regulations.



3.1 INTRODUCTION OF LCD ICONS

Icons	Meaning	Icons	Meaning
	Auto		Airflow direction
	Cooling		Fan speed
	Dry		Sleep
	Fan		Auto fan
	Heating		Temp
	Light (optional only)		Clock
	Heater (optional only)		Timer
	Lock		

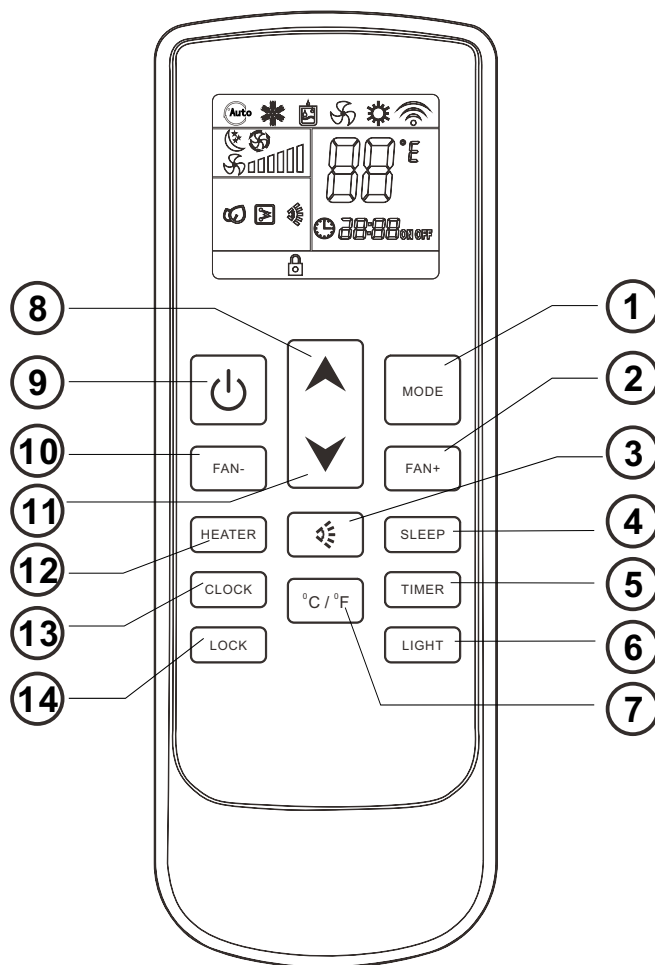







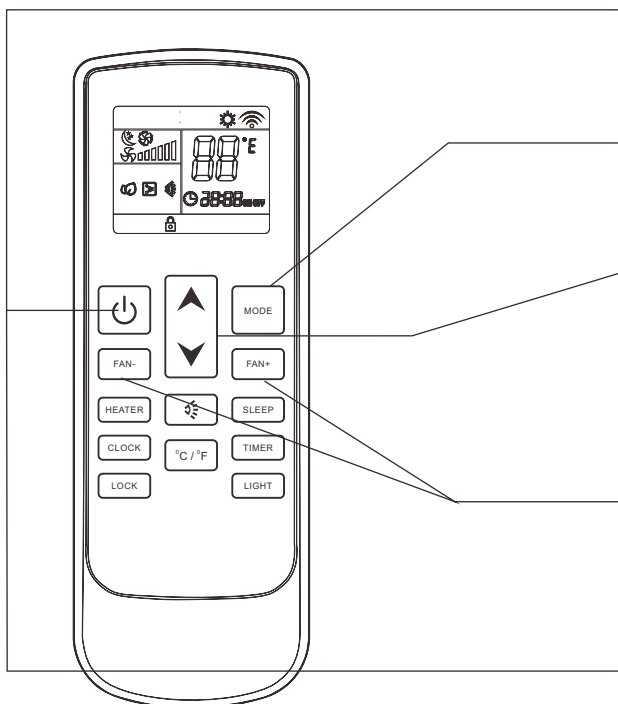

3.2 REMOTE CONTROL FUNCTIONS

- ① **MODE BUTTON:** Set up the air conditioner operating mode
- ② **FAN SPEED BUTTON:** Set up the fan speed
- ③ **LOUVER SWING BUTTON:** Adjust the airflow direction
- ④ **SLEEP BUTTON:** Automatically adjusting the setting temperature according the circadian rule.
- ⑤ **TIMER BUTTON:** Set up the time the air conditioner starts;
Set up the time the air conditioner stops.
- ⑥ **LIGHT BUTTON**(optional only): Switch on the light or UPI than the unit has this function
- ⑦ **TEMP BUTTON:** Set temperature unit to °C or °F
- ⑧ **UP BUTTON:** Increase the temperature and time
- ⑨ **ON/OFF BUTTON:** Turn on or turn off the air conditioner
- ⑩ **FAN SPEED BUTTON:** Set up the fan speed down
- ⑪ **DOWN BUTTON:** Decrease the temperature and time
- ⑫ **ELECTRICAL HEATER BUTTON**(optional only): Turns on the integrated electric heat to boost heating performances when outdoor temperatures are below 5°C and additional heat is required.
- ⑬ **CLOCK BUTTON:** Adjust the clock
- ⑭ **LOCK BUTTON:** Lock the remote control set

3.3 HEATING MODE









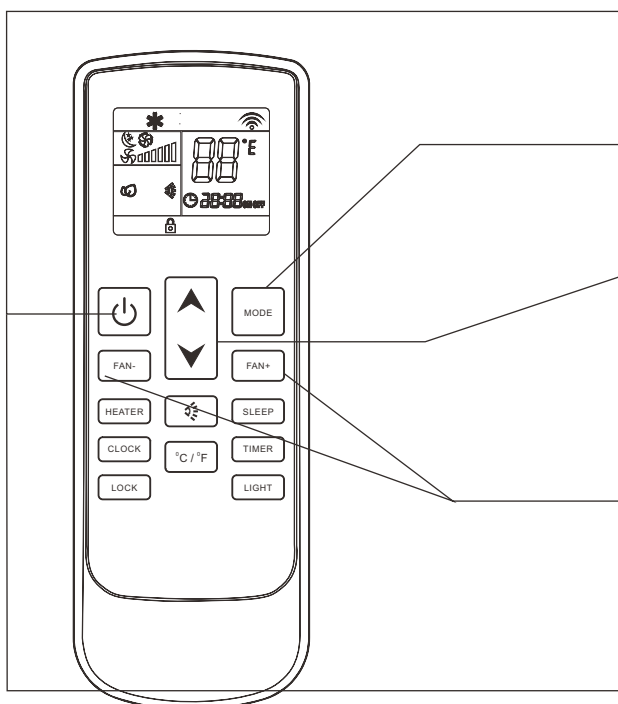

Sequence of the operations

- 1** Press the **ON/OFF** button "  ", switch on the air conditioner, it will run by memory mode.
- 2** Press the **MODE** button, set up the mode to heat "  ", the air conditioner will run in heating.
- 3** Press **UP** "  " or **DOWN** "  " button, to adjust the setting up temperature.
- 4** Press the **FAN SPEED** button " **FAN+** " or " **FAN-** " , set up the fan speed, "  " is low speed, "  " is middle speed, "  " is high speed, "  " is auto speed.
For auto fan, the speed is chosen by the difference of room temperature and setting temperature.
- 5** Press the **ON/OFF** button "  " , switch off the air conditioner.
Next time when this button is pressed, the air conditioner will operates in this mode by memory.

3.4 COOLING MODE



Sequence of the operations

- 1** Press the **ON/OFF** button "  " , switch on the air conditioner, it will run by memory mode.
- 2** Press the **MODE** button, set up the mode to cool "  " , the air conditioner will run in cooling.
- 3** Press **UP** "  " or **DOWN** "  " button, to adjust the setting up temperature.
- 4** Press the **FAN SPEED** button " **FAN+** " or " **FAN-** " , set up the fan speed, "  " is low speed, "  " is middle speed, "  " is high speed, "  " is auto speed.
For auto fan, the speed is chosen by the difference of room temperature and setting temperature.
- 5** Press the **ON/OFF** button "  " , switch off the air conditioner.
Next time when this button is pressed, the air conditioner will operates in this mode by memory.

3.5 DRY MODE

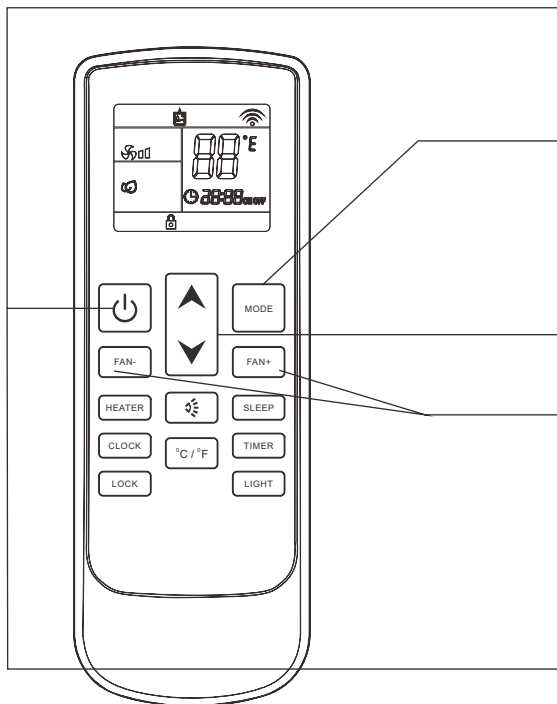

Sequence of the operations

- 1** Press the **ON/OFF** button "⏻", switch on the air conditioner, it will run by memory mode.
- 2** Press the **MODE** button, set up the mode to dry "☁", the air conditioner will run in dehumidifying.
- 3** Press **UP** "▲" or **DOWN** "▼" button, to adjust the setting up temperature.
- 4** **FAN SPEED** button "FAN+" or "FAN-" is disable, indoor fan speed always is low in dry mode.
- 5** Press the **ON/OFF** button "⏻", switch off the air conditioner. Next time when this button is pressed, the air conditioner will operates in this mode by memory.

3.6 FAN MODE

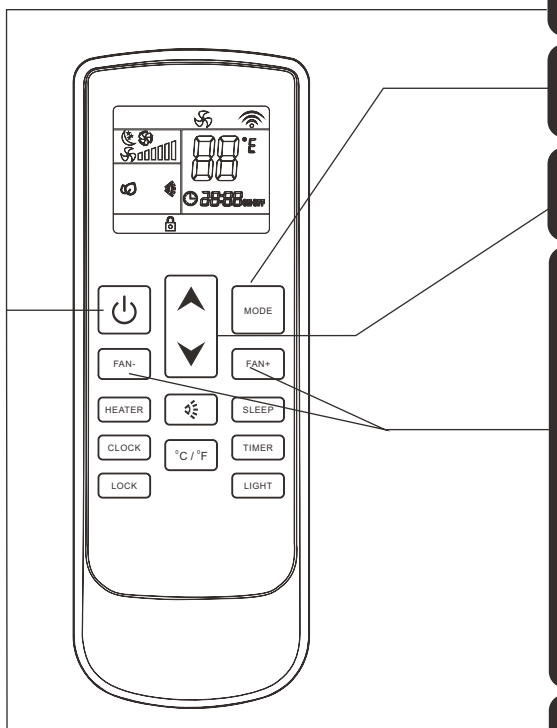

Sequence of the operations

- 1** Press the **ON/OFF** button "⏻", switch on the air conditioner, it will run by memory mode.
- 2** Press the **MODE** button, set up the mode to fan "🌀", the air conditioner will run in fan.
- 3** Press **UP** "▲" or **DOWN** "▼" button, to adjust the setting up temperature.
- 4** Press the **FAN SPEED** button "FAN+" or "FAN-", set up the fan speed, "🌀" is low speed, "🌀🌀" is middle speed, "🌀🌀🌀" is high speed, "🌀🌀🌀🌀" is auto speed. For auto fan, the speed is chosen by the difference of room temperature and setting temperature.
 Room temperature-setting temperature > 5°C high speed.
 Room temperature-setting temperature > 3°C middle speed.
 Room temperature-setting temperature > 1°C low speed.
- 5** Press the **ON/OFF** button "⏻", switch off the air conditioner. Next time when this button is pressed, the air conditioner will operates in this mode by memory.

3.7 SLEEP MODE

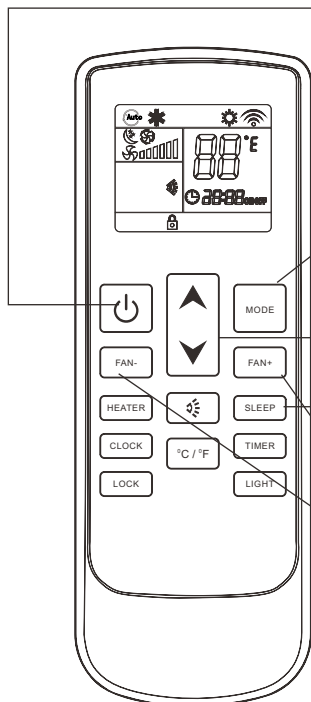

Sequence of the operations

1

Press the **ON/OFF** button "⏻", switch on the air conditioner, it will run by memory mode.

2

Press the **MODE** button, set up the mode to cool "❄️" / heat "🔥" (heat pump) / auto "🔄", the air conditioner will run in setting mode.

3

Press **UP** "▲" or **DOWN** "▼" button, to adjust the setting up temperature.

4

Press the **SLEEP** button, this icon will display on LCD, sleep function is set up; press it again, cancel the sleep function.

5

If the sleep function is launched, the fan speed is steady in low speed.

3.8 AUTO MODE

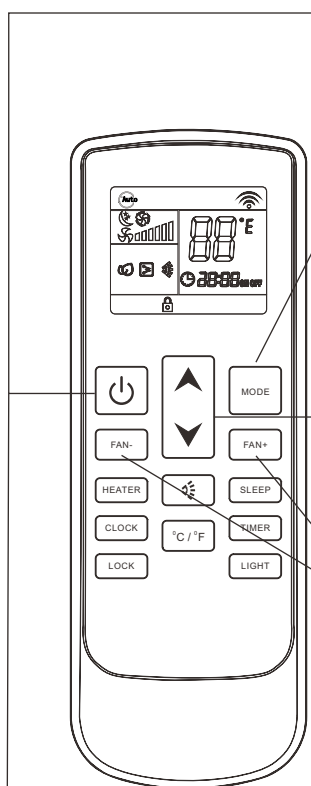

Sequence of the operations

1

Press the **ON/OFF** button "⏻", switch on the air conditioner, it will run by memory mode.

2

Press the **MODE** button, set up the mode to auto "🔄", the air conditioner will run in auto mode. (Reference to "emergency operation")

3

According to the difference of room temperature and setting temperature automatically choose the running mode (cool, heat, fan). The temperature setting button UP "▲" and DOWN "▼" are disable. When room temperature $\leq 20^{\circ}\text{C}$, run with heat mode. When $20^{\circ}\text{C} < \text{room temperature} < 25^{\circ}\text{C}$, run with fan mode. When room temperature $\geq 25^{\circ}\text{C}$, run with cool mode.

4

Press the **FAN SPEED** button "FAN+" or "FAN-", set up the fan speed, "🌀" is low speed, "🌀🌀" is middle speed, "🌀🌀🌀" is high speed, "🌀" is auto speed. For auto fan, the speed is chosen by the difference of room temperature and setting temperature.







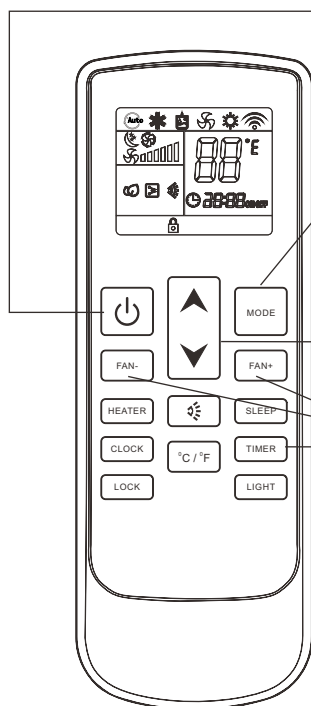

5

Press the **ON/OFF** button "⏻", switch off the air conditioner. Next time when this button is pressed, the air conditioner will operate in this mode by memory.

3.9 TIMER OFF FUNCTION





Sequence of the operations

- 1** Press the **ON/OFF** button "  ", switch on the air conditioner, it will run by memory mode.
- 2** Press the **MODE** button set up the mode to which you want.
- 3** Press **UP** "  " or **DOWN** "  " button, to adjust the setting up temperature.
- 4** Press the **FAN SPEED** button " **FAN+** " or " **FAN-** ", set up the fan speed, "  " is low speed, "  " is middle speed, "  " is high speed, "  " is auto speed.
For auto fan, the speed is chosen by the difference of room temperature and setting temperature.
- 5** Press the **TIME** button " **TIMER** ", set up the time air conditioner switch off.
Press the button "  " each time, adjusting up 1 hour; Press the button "  " each time, adjusting up 10 minutes; press the timer button to confirm the data entered.
When the time is over, the air conditioner will be switched off automatically.
If press this button again before the air conditioner switch off, the timer off setting will cancelled.

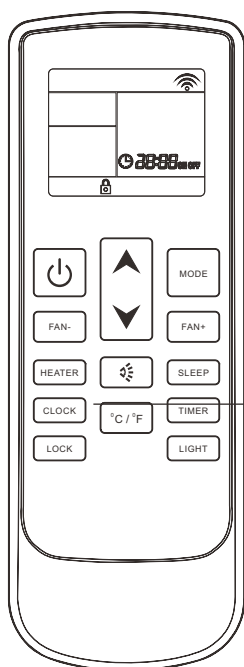
3.10 TIMER ON FUNCTION



Sequence of the operations

- 1** The air conditioner is switched off.
- 2** Press the **TIME** button " **TIMER** ", set up the time which the air conditioner switch on.
Press the button "  " each time, adjusting up 1 hour; Press the button "  " each time, adjusting up 10 minutes. Set up the operation **MODE**, **TEMPERATURE**, **FAN SPEED** etc., press the timer button to confirm the date entered. When the time is arrived, the air conditioner will start automatically. If the **TIMER ON** button is pressed again, the **TIMER ON** setting will be cancelled.

3.11 ELECTRICAL HEATER FUNCTION(optional only)

Sequence of the operations

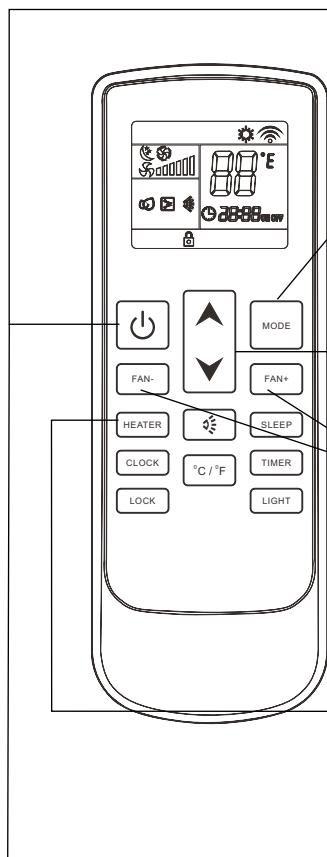

1

Press the **ON/OFF** button "  ", switch on the air conditioner, it will run by memory mode.





2

Press the **MODE** button set up the mode to heat "  ", the unit will run in heating.

3

Press **UP** "  " or **DOWN** "  " button, to adjust the setting up temperature.

4

Press the **FAN SPEED** button " **FAN+** " or " **FAN-** ", set up the fan speed, "  " is low speed, "  " is middle speed, "  " is high speed, "  " is auto speed.

For auto fan, the speed is chosen by the difference of room temperature and setting temperature.

5

Press the assistant **ELECTRICAL HEAT** button " **HEATER** ", the icon will display on the LCD, starting the assistant heat; press this button again, stop the assistant heat.

6

Press the **ON/OFF** button "  ", switch off the unit.

Next time when this button is pressed, the unit will operate in this mode by memory.

3.12 On board control function

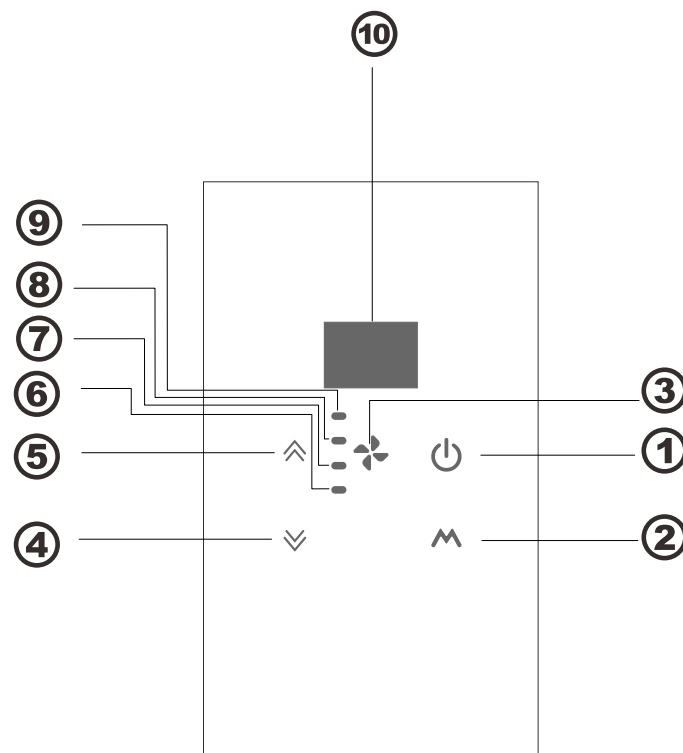

- ① **ON/OFF BUTTON:** Turn on or turn off the air conditioner
- ② **MODE BUTTON:** Set up the air conditioner operating mode
- ③ **FAN SPEED BUTTON:** Set up the fan speed
- ④ **DOWN BUTTON:** Decrease the temperature and time
- ⑤ **UP BUTTON:** Increase the temperature and time
- ⑥ **HIGH SPEED LED:** Signal the high speed working state
- ⑦ **MIDDLE SPEED LED:** Signal the middle speed working state
- ⑧ **LOW SPEED LED:** Signal the low speed working state
- ⑨ **AUTO FAN LED:** Signal the automatic fan state

If you select the AUTO speed, the fan speed is according with the room temperature and setting temperature.

Room temperature-setting temperature $> 5^{\circ}\text{C}$, high speed;

Room temperature-setting temperature $> 3^{\circ}\text{C}$, middle speed;

Room temperature-setting temperature $> 1^{\circ}\text{C}$, low speed.

⑩ **Temperature display window**

The display will show both setting temperature and ambient temperature.

After adjusting the setting temperature, the setting temperature will flash

15 minutes on the display, then the display will show the ambient temperature

for 70 seconds. After that, the display will be off until next adjustment.

3.13 WiFi Connection and instruction for use

- Downloading of Smart APP

Search and download "Smart Life" in major application markets or scan the QR code below to download the App.



- Register the APP account and log in, add equipment and set WIFI network according to the prompts;
- WIFI Intelligent remote control
- Matching:
Press the "Louver Swing" button of the remote control five times within 5s to enter the distribution network.
For the first time, it is slow flash distribution network.
Press the "Louver Swing" button five times within 5s to enter the fast flash.
After the pairing is successful, press the "Louver Swing" button five times within 5s to clear the WIFI pairing.

3.14 Install and change the battery

- Open the cover of battery, hold the hook and lightly pull up.
- Insert the battery(AAA,2pecs), the positive must be same with the mark on the plastic surface.
- Reinstall the cover of battery.
- Inspection: if press ON/OFF button "⏻". no icons are displayed, please install the battery again.

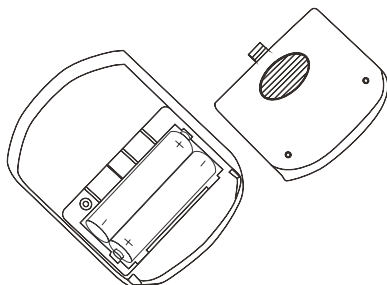

3.15 Fresh air system

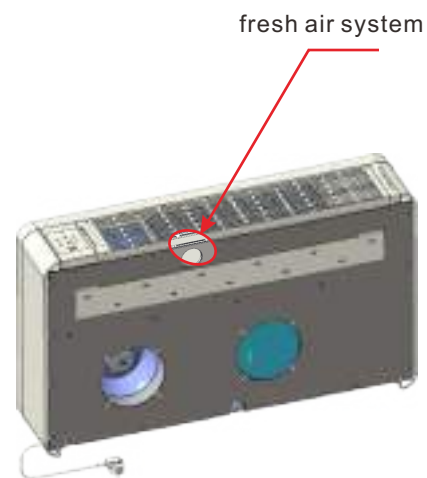

Open position

Close position

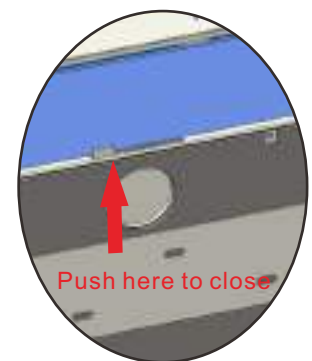
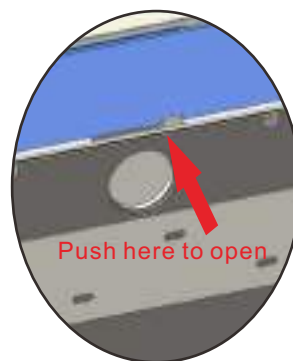

When the fresh air system is open the air conditioner will change the room air automatically: in this way new clean and fresh air will intake to the room. You can open or close the fresh air system any moment. If the air fresh system is close the air conditioner performances are more high so we suggest to maintain the fresh air system closed and open it just a few minutes per day.

3.16 MAINTENANCE
(P15, P16, P17, P18)

FILTERS CLEANING:

The filters should be regularly cleaned to keep the air conditioner running efficiently. Clean the filters every two weeks.

How to proceed:

- Disconnect the air conditioner from the electrical supply.
- Extract the filter grating.(P15) on the same direction of the arrow.
- Take out the filter as shown P17.
- Proceed to wash them (not use hot water) and only when they are dried replace them in the same way.

ATTENTION: Do not use the air conditioner without filters as it could seriously damage the air conditioner.

EXTERNAL CLEANING:

- Disconnect the air conditioner from the electrical supply.
- Wipe external surfaces clean with a damp cloth only.
- Do not use an abrasive cloth and/ or solvents, as this may damage the surfaces.
- Do not use excessively wet cloths or sponges, as water stagnation could damage the air conditioner and compromise safety.

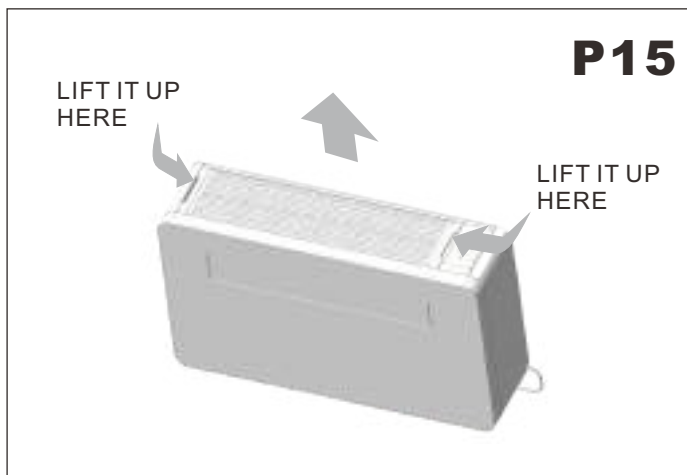
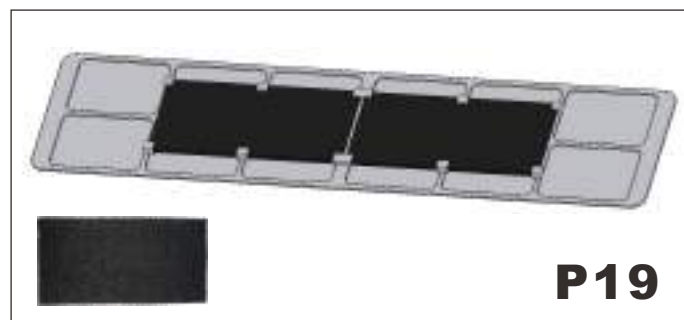
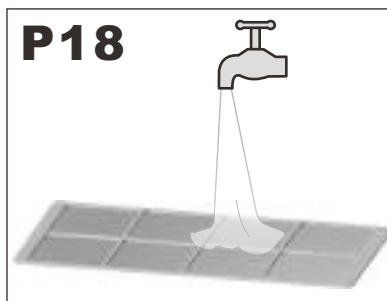
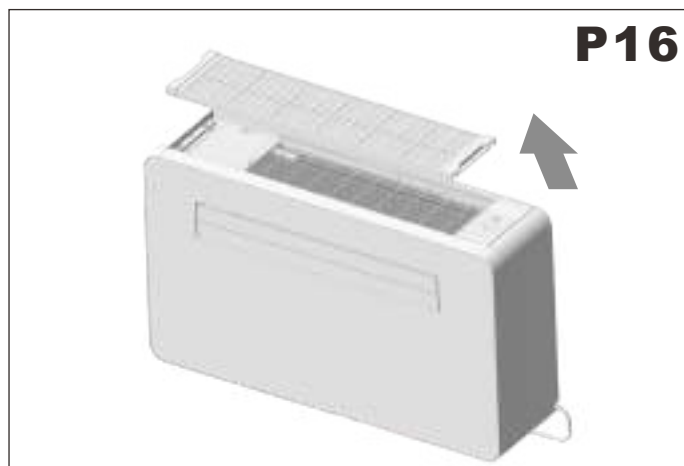

ACTIVE CARBON FILTER

The unit includes active carbon filter, which not only has the function of eliminating suspended matters that a common mechanical filter has, but also can eliminate foreign matters such as free chlorine, odors, colors and toxic matters that are difficult to filter out by using conventional approaches.

With active carbon filter, the room air would be fresh and good for the body health. Is advisable to change them every three month, because it's not possible to wash or clean them.

3.17 PROBLEM SOLVING**PROBLEM POSSIBLE CAUSES**

- The air conditioner does not work.
- The air conditioner does not refrigerate the room
- Strange smell in the room. Water drips from the air conditioner.
- The remote control does not work.
- The air conditioner does not work for 3 minutes when switched on.

POSSIBLE SOLUTIONS

1. Wrong setting of the timer/ Check it.
2. Problems on the power supply/ Call the service center.
3. The filter could be dirty/ Clean it.
4. The room temperature is too high/ Wait until the temperature goes down,
5. The temperature is not properly set/ Check it.
6. The grids could be obstructed/ Check and remove the eventual obstacles.
 - Dampness in the room, coming from walls, carpets, furnishing or similar
 - Wrong installation of the air conditioner
 - Wrong connection of the drainage pipe
 - Exhausted batteries
 - Wrong insertion of the batteries inside the remote control
 - Protection of the air conditioner. Wait for 3 minutes and the air conditioner will start to work again.



If the supply cord damaged, it must be replaced by manufacturer or its service agent or a similarly qualified person in order to avoid a hazard.

The max operation temperature for the air conditioner (max cooling: outdoor DB 43°C/ WB 26°C, indoor DB 32°C/ WB 23°C; min heating: outdoor DB -5°C/ WB -6°C, indoor DB 20°C)

This appliance is not intended for use by persons (including children) with reduced physical, sensory or mental capabilities, or lack of experience and knowledge, unless they have been given supervision or instruction concerning use of the appliance by a person responsible for their safety. Children should be supervised to ensure that they do not play with the appliance.

List of Error Codes

Codes displayed on monitor LED	Faults
A1	Indoor machine EE fault
A2	Indoor fan fault
A4	Indoor coil temperature sensor fault
A5	Indoor ambient temperature sensor fault
E5	Four -way valve commutation fault
E6	Fluorine deficiency fault
A8	Outdoor EE fault
b4	Compressor starting abnormal (phase failure, reverse)
b5	Compressor out-of-step fault
b6	IPM module fault
b8	Exhaust temperature sensor fault
C2	Outdoor coil temperature sensor fault
C3	Outdoor ambient temperature sensor fault
C4	Outdoor DC fan fault
d1	Outdoor machine AC current protection shutdown
d2	Compressor phase current protection shutdown (reverse)
d3	Outdoor machine AC voltage over-high/over-low protection
d4	DC busbar voltage over-high/over-low voltage protection
d5	IPM over-high temperature protection shutdown
d6	Exhaust temperature overheat protection shutdown
d7	Cooling indoor coil anti-freezing protection shutdown
d8	Cooling outdoor coil overheat protection shutdown
E1	Cooling outdoor coil overheat protection shutdown
E2	Cooling outdoor ambient temperature over-low protection shutdown
E3	Heating outdoor ambient temperature over-high protection shutdown
C5	Driven busbar overvoltage protection
C6	Driven busbar undervoltage protection
C7	Driven phase current overcurrent fault
C8	Abnormal phase current sampling

Smaltimento delle apparecchiature obsolete
Disposal of your old appliance
Entsorgung von Altgeräten
Élimination des appareils obsolètes
Como deshacerse de aparatos eléctricos y electrónicos viejos
Eliminação do seu antigo aparelho



IT

Smaltimento delle apparecchiature obsolete

1. Quando su n prodotto è riportato il simbolo di un bidone della spazzatura sbarrato da una croce significa che il prodotto è coperto dalla Direttiva Europea 2002/96/EC.
2. Tutti i prodotti elettrici ed elettronici dovrebbero essere smaltiti separatamente rispetto alla raccolta differenziata municipale, mediante impianti di raccolta specifici designati dal governo o dalle autorità locali.
3. Il corretto smaltimento delle apparecchiature obsolete contribuisce a prevenire possibili conseguenze negative sulla salute umana e sull'ambiente.
4. Per informazioni più dettagliate sullo smaltimento delle apparecchiature obsolete, contattare il comune, il servizio di smaltimento rifiuti o il negozio in cui è stato acquistato il prodotto.

FR

Élimination des appareils obsolètes

1. Quand figure sur un produit le symbole représentant une poubelle barrée d'une croix, cela indique que le produit est assujéti à la Directive européenne 2002/96/EC.
2. Tous les appareils et composants électriques et électroniques doivent être éliminés auprès de déchetteries spécifiques indiquées par les pouvoirs publics nationaux ou par les autorités locales.
3. La bonne élimination des appareils obsolètes contribue à prévenir les conséquences dommageables pour la santé des personnes et pour l'environnement.
4. Pour plus d'informations concernant l'élimination des appareils obsolètes, veuillez contacter votre mairie, le service d'élimination des ordures ou encore le magasin où le produit a été acheté.

UK

Disposal of your old appliance

1. When this crossed-out bin symbol appears on a product it means that the product is covered by European Directive 2002/96/EC.
2. All electrical and electronic products should be disposed of separately from the municipal waste stream via specific collection facilities designated by the government or the local authorities.
3. Proper disposal of your old appliance will help prevent potential negative consequences for the environment and human health.
4. For more detailed information about disposal of your old appliance, please contact your municipality, the waste disposal service or the shop where you purchased the product.

ES

Como deshacerse de aparatos eléctricos y electrónicos viejos

1. Si en un producto aparece el símbolo de un contenedor de basura tachado, significa que éste se acoge a la Directiva 2002/96/EC.
2. Los aparatos eléctricos no se deben desechar junto con los residuos domésticos, sino a través de puntos de recogida designados por el gobierno o las autoridades locales.
3. La correcta recogida y tratamiento de los dispositivos inservibles contribuye a evitar riesgos potenciales para el medio ambiente y la salud pública.
4. Para obtener más información sobre cómo deshacerse de sus aparatos eléctricos y electrónicos viejos, póngase en contacto con su ayuntamiento, el servicio de recogida de basuras o el establecimiento donde adquirió el producto.

DE

Entsorgung von Altgeräten

1. Wenn dieses Symbol eines durchgestrichenen Abfalleimers auf einem Produkt angebracht ist, unterliegt dieses Produkt der europäischen Richtlinie 2002/96/EC.
2. Alle Elektro- und Elektronik-Altgeräte müssen getrennt vom Hausmüll über dafür staatlich vorgesehene Stellen entsorgt werden.
3. Eine ordnungsgemäße Entsorgung des Altgeräts trägt dazu bei, Schäden an der Umwelt und der menschlichen Gesundheit zu vermeiden.
4. Weitere Informationen zur Entsorgung des Altgeräts erhalten Sie bei der Stadtverwaltung, beim Entsorgungsamt oder in dem Geschäft, in dem Sie das Produkt erworben haben.

PT

Eliminação do seu antigo aparelho

1. Quando este símbolo de caixote do lixo com uma cruz em cima estiver afixado a um produto, significa que o produto se encontra abrangido pela Directiva Europeia 2002/96/EC.
2. Todos os produtos eléctricos e electrónicos devem ser eliminados separadamente do lixo doméstico através de pontos de recolha designados para o efeito pelo governo ou pelas autoridades locais.
3. A eliminação correcta do seu aparelho antigo ajuda a evitar potenciais consequências negativas para o ambiente e para a saúde humana.
4. Para obter informações mais detalhadas acerca da eliminação do seu aparelho antigo, contacte as autoridades locais, um serviço de eliminação de resíduos ou a loja onde comprou o produto.